

**Features**

- Blocks Geomagnetic storm Induced Currents (GIC) and EMP-E3
- Capacitor blocking – all harmonics stopped regardless of solar storm or EMP size
- Prevention of transformer half cycle saturation, Harmonic generation and thermal damage
- Transformer neutral line always tied to ground
- Automatic sensing of GIC or EMP/E3 induced quasi-DC currents in transformer neutral
- Continuous operation even through ground faults
- System operator override of automatic protection
- System operator controlled switch reclose
- EMP/IEMI protected electronics
- Factory assembled solution ready-for-installation on concrete piers
- Ferro resonance protection included
- DC switch

**HIGH VOLTAGE TRANSFORMER PROTECTIONS SPECIFICATIONS (GIC & EMP/IEMI PROTECTION)**

Transformer Application	Specifications
Transformer Ratings	115 kV to 765 kV, 150 kV Neutral BIL
Transformer Configuration	Neutral of "Y" type
Neutral Quasi DC Current Attenuation	> 40 db below 0.6 Hz
Neutral GIC Current Sensing Trigger	Selectable: 6 to 500 Amps
GIC Induced Harmonic Sensing Trigger	Selectable: 1.5%, 3%, 5%, 10%
Input Power	120 volts DC

GIC – Geomagnetic Induced Current THD – Total Harmonic Distortion EMP – Electromagnetic Pulse IEMI – Intentional Electromagnetic Interference



1660 S Hwy 100, Suite 130 • Minneapolis, MN 55413  
 T: 952.545.2051 • F: 952.545.2216  
[www.emprimus.com](http://www.emprimus.com)  
 ©2011 Emprimus • Patents Pending

**EMPRIMUS SOLIDGROUND™  
 NEUTRAL DC BLOCKING SYSTEM**

- Blocks Geomagnetic storm Induced Currents (GIC) and EMP-E3
- Eliminates voltage harmonics to the Grid • Protection switches in only when needed



©2011 Emprimus • Patents Pending

The Emprimus SolidGround™ Neutral DC Blocking System automatically blocks DC currents from flowing in the neutral of large power transformers protecting against Geomagnetic Storm Induced Currents (GIC) and Electromagnetic Pulse (EMP) induced currents of any size.

Various solutions to remediate ground currents in grid transformer neutrals have been examined – all involving placing some form of impedance continuously in the transformer neutral. Although there are varying degrees of effectiveness, all have the disadvantage of continuously modifying transformer operations from the designed operating condition of a solidly grounded neutral conductor – modifying operating conditions, relay settings and system reliability. And, resistor solutions do not work effectively for large geomagnetic storms because they only partially reduce GIC.

Emprimus SolidGround™ cost effectively solidly grounds the transformer at all times. Under normal conditions, presence of this protection is completely transparent to Grid operations.

A top level diagram of the SolidGround™ system architecture is shown in Fig. 1.

### Sequence of Operations

The switch “S” is two separate switches: a high speed grounding switch and a DC disconnect. The DC disconnect switch is designed to break DC and quasi-DC currents. (The voltage ratings of the commercially available DC disconnect switches are lower than the neutral voltages expected during ground faults.) This switch assembly is comprised of a DC disconnect switch connected in series with an AC grounding switch.

When a flow of GIC is detected, the switch control logic opens the switch assembly before the neutral voltage exceeds the rating of the DC disconnect switch. The AC grounding switch opens nearly simultaneously. Once both switches are opened, the DC disconnect switch is reclosed but the grounding switch remains open until a system operator declares the GIC event to be over. The capacitor then blocks the DC and quasi-DC ground currents in the transformer neutral while providing continuous AC grounding. A series resistor is utilized to effectively damp neutral and phase transients (see Figs. 2-3). The AC grounding switch is automatically closed if a fault is detected. The system operator then closes the grounding switch by SCADA to bypass

the blocking capacitor and directly grounds the transformer.

Also, the system operator has the ability to insert the blocking capacitor by initiating the DC disconnect switch and grounding switch sequence by SCADA.

### Blocking Components

“Rsh” in the diagram is a very low impedance, high capacity heavy duty brass shunt resistor utilized for measuring DC and quasi-DC current in the transformer neutral. The capacitive voltage transformer (CVT) provides waveform information to the SolidGround™ electronics (see Fig. 4) for harmonic distortion computation. When abnormal ground current and/or harmonic distortion is detected, the switches “S” are opened to force the ground through the resistor and capacitor. The resistor is a high-power, low-impedance power resistor rated at 50 KW. The capacitor bank is made up of twenty-eight 200 kVAR units, comprising 5600 kVAR and rated at 2.4kV. In the very unlikely event of a line fault simultaneously with a GIC event, a very fast MOV surge arrester assembly is employed to protect the RC combination.

Historical data shows that a ground current event of sufficient magnitude to need mitigation may occur once in 14 months on the average. When the SolidGround remediation was in place for 24 hours (a conservative time), the transformer is solidly AC

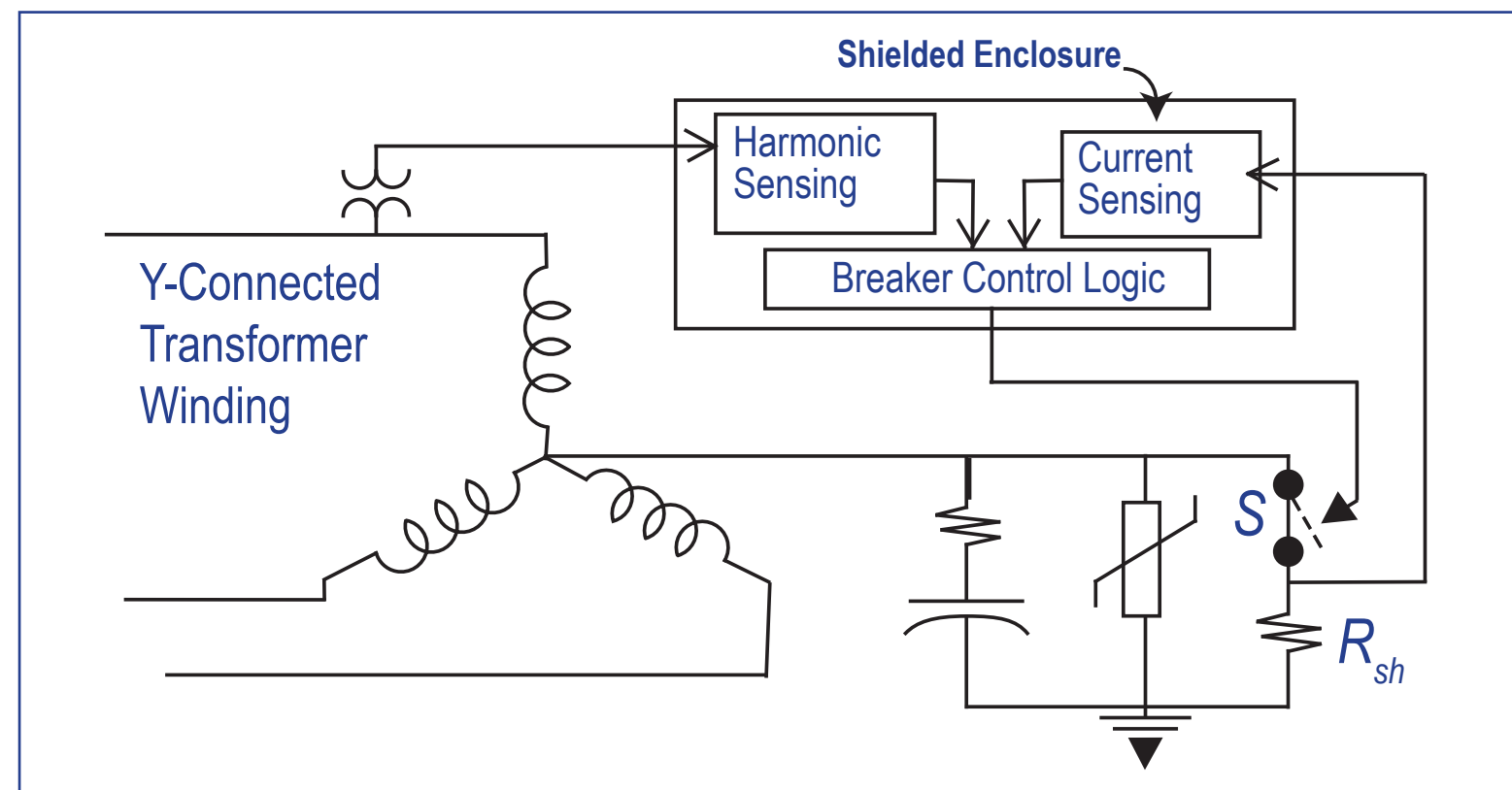

Fig. 1

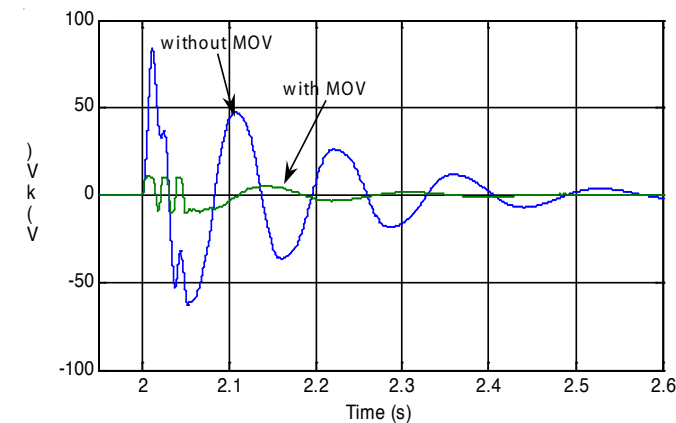

Fig. 2 Variation of neutral voltage with and without MOV

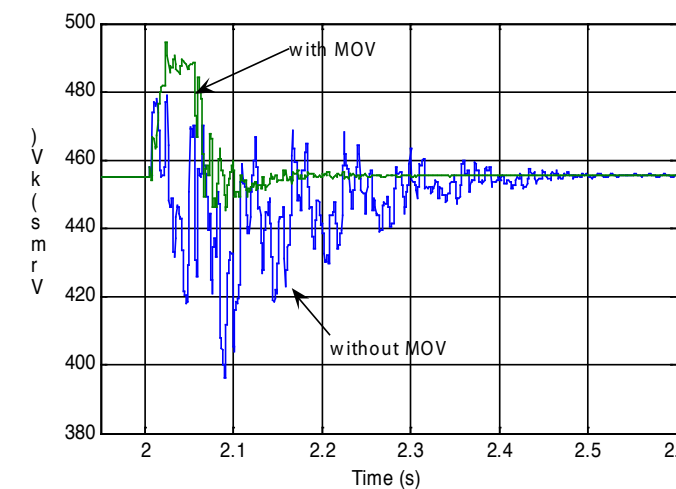

Fig. 3 Variation of phase-C RMS voltage on bus-5 during the fault, with and without MOV

and DC grounded 99.8% of the time. During mitigation, the capacitor blocks the DC and quasi-DC currents, while providing seamless AC grounding. Other blocking schemes that employ only resistors only reduce, but do not eliminate the DC currents, and result in more significant harmonic and ferro-resonance remnants.

The SolidGround™ system is engineered and shipped pre-assembled from the factory, minimizing installation cost and effort. Typical installations involve concrete piers, the bolting of extension legs, completing the electrical connections, and commissioning. The system is designed to work on all HV class transformers.

The University of Manitoba, using one of the most powerful simulation tools in the world, has conducted a series of simulations to verify the performance of the SolidGround™ system to GIC remediation. Fig. 4 and 5 show how the SolidGround™ system with the MOV feature controls the neutral and phase voltages in the event that a fault occurs simultaneously with a GIC remediation switching period.

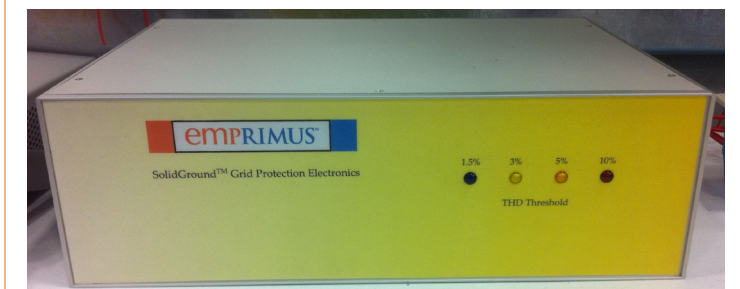

Fig. 4 Emprimus Solid Ground™ Control Electronics



Above: Addition of properly located surge arresters gives protection to the E1 and E2 portion of the EMP spectrum